



Mitigation of Voltage Complication by A Novel Control Algorithm Based Dynamic Voltage Restorer

Authors

K.Ashok Kumar¹, A. Sitaram²

¹Student Member, Dept. of EEE, BVCITS, Amalapuram,

Email: *kenguva.224@gmail.com*

²M.Tech, Asst. Professor, Dept. of EEE, BVCITS, Amalapuram,

Email: *sitaram235@gmail.com*

Abstract

This project gives the systematic procedure of the modeling and simulation of a Dynamic Voltage Restorer (DVR) for power quality problem, voltage sag based on Pulse Width Modulation (PWM) technique. This problem is reduced by using custom power devices. The control of the Voltage Source Converter (VSC) is done with the help of PWM. The proposed DVR is modeled and simulated by using MATLAB/Simulink environment.

Keywords: *Power Quality, DVR, voltage sags/swells, VSI, Synchronous Reference Frame Theory, MATLAB/SIMULINK.*

INTRODUCTION

Power distribution systems, ideally, should provide their customers with an uninterrupted flow of energy at smooth sinusoidal voltage at the contracted magnitude level and frequency^[1] however, in practice, power systems, especially the distribution systems, have numerous nonlinear loads, which significantly affect the quality of power supplies. As a result of the nonlinear loads, the purity of the waveform of supplies is lost. This ends up producing many power quality problems. Apart from nonlinear loads, some system events, both usual (e.g. capacitor switching, motor starting) and unusual (e.g. faults) could also inflict power quality problems^[2]. Power quality phenomenon or power quality disturbance can be defined as the deviation of the voltage and the current from its ideal waveform. Faults at either the transmission or distribution level may cause voltage sag or swell in the entire

system or a large part of it. Also, under heavy load conditions, a significant voltage drop may occur in the system. Voltage sag and swell can cause sensitive equipment to fail, shutdown and create a large current unbalance. These effects can incur a lot of expensive from the customer and cause equipment damage^[1]. The voltage dip magnitude is ranged from 10% to 90% of nominal voltage and with duration from half a cycle to 1 min and *swell* is defined as an increase in rms voltage or current at the power frequency for durations from 0.5 cycles to 1 min. typical magnitudes are between 1.1 and 1.8 p.u^[2]. There are many different methods to mitigate voltage sags and swells, but the use of a custom power device is considered to be the most efficient method, e.g. FACTS for transmission systems which improve the power transfer capabilities and stability margins. The term custom power pertains to the use of power

electronics controller in a distribution system^[10], especially, to deal with various power quality problems. Custom power assures customers to get pre-specified quality and reliability of supply. This pre-specified quality may contain a combination of specifications of the following: low phase unbalance, no power interruptions, low flicker at the load voltage, and low harmonic distortion in load voltage, magnitude and duration of over voltages and under voltages within specified limits, acceptance of fluctuations, and poor factor loads without significant effect on the terminal voltage.

There are different types of Custom Power devices used in electrical network to improve power quality problems. Each of the devices has its own benefits and limitations. A few of these reasons are as follows. The SVC pre-dates the DVR, but the DVR is still preferred because the SVC has no ability to control active power flow [3]. Another reason include that the DVR has a higher energy capacity compared to the SMES and UPS devices. Furthermore, the DVR is smaller in size and cost is less compared to the DSTATCOM and other custom power devices. Based on these reasons, it is no surprise that the DVR is widely considered as an effective custom power device in mitigating voltage sags. In addition to voltage sags and swells compensation, DVR can also add other features such as harmonics and Power Factor correction. Compared to the other devices, the DVR is clearly considered to be one of the best economic solutions for its size and capabilities^[4].

The organization of the paper is as follows. In section II, the constructional part of the DVR is briefly described, the operating principle and the voltage injection capabilities of the DVR is discussed in section III, proposed control algorithm enumerated in section IV and the detailed description of MATLAB Simulation model along with its performance in electrical network discussed in section V and section VI respectively.

DYNAMIC VOLTAGE RESTORER (DVR)

DVR is a Custom Power Device used to eliminate supply side voltage disturbances. DVR also known as Static Series Compensator maintains the load voltage at a desired magnitude and phase by compensating the voltage sags/swells and voltage unbalances presented at the point of common coupling.

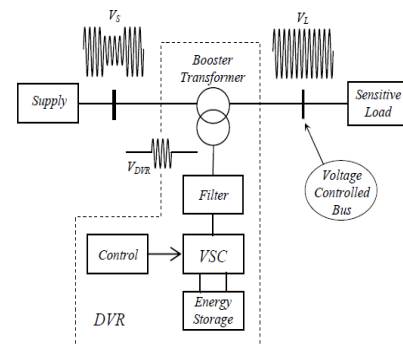

Figure-1: DVR series connected topology

The power circuit of the DVR is shown in Fig. 1.

The DVR consists of 6 major parts:-

a) Voltage Source Inverter (VSI):

These inverters have low voltage ratings and high current ratings as step up transformers are used to boost up the injected voltage.

b) Injection Transformers:

Three single phase injection transformers are connected in delta/open winding to the distribution line. These transformers can be also connected in star/open winding. The star/open winding allows injection of positive, negative and zero sequence voltages whereas delta/open winding only allows positive and negative sequence voltage injection.

c) Passive Filters:

Passive filters are placed at the high voltage side of the DVR to filter the harmonics. These filters are placed at the high voltage side as placing the filters at the inverter side introduces phase angle shift which can disrupt the control algorithm.

d) Energy storage:

Batteries, flywheels or SMEs can be used to provide real power for compensation. Compensation using real power is essential when large voltage sag occurs.

e) Capacitor:

DVR has a large DC capacitor to ensure stiff DC voltage input to inverter.

f) By-Pass Switch:

If the over current on the load side exceeds a permissible limit due to short circuit on the load or large inrush current, the DVR will be isolated from the system by using the bypass switches and supplying another path for current.

OPERATION OF DVR

The schematic diagram of a DVR is shown in Figure-2. Three phase source voltages (V_{sa} , V_{sb} , and V_{sc}) are connected to the 3-phase critical load through series impedance (Z_a , Z_b , Z_c) and an injection transformer in each phase. The terminal voltages (V_{ta} , V_{tb} , V_{tc}) have power quality problems and the DVR injects compensating voltages (V_{Ca} , V_{Cb} , V_{Cc}) through an injection transformer to get undistorted and balanced load voltages (V_{La} , V_{Lb} , V_{Lc}). The DVR is implemented using a three leg voltage source inverter with IGBTs along with a dc capacitor (C_{dc}). A ripple filter (L_r , C_r) is used to filter the switching ripple in the injected voltage. The considered load, sensitive to power quality problems is a three-phase balanced lagging power factor load. A self-supported DVR does not need any active power during steady state because the voltage injected is in quadrature with the feeder current.

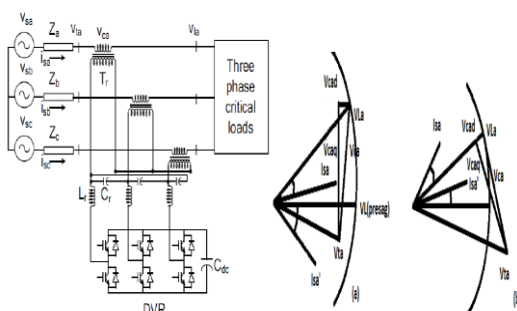

Figure-2 (a) Schematic diagram of DVR Figure-3: Phasor Diagram for (a) Voltage Sag (b) Voltage Swell

The DVR operation for the compensation of sag, swell in supply voltages is shown in Figure-3. Before sag the load voltages and currents are represented as V_L (presag) and I_{sa} as shown in

Figure-3 (a). After the sag event, the terminal voltage (V_{ta}) is gets lower in magnitude and lags the presag voltage by some angle. The DVR injects a compensating voltage (V_{Ca}) to maintain the load voltage (V_L) at the rated magnitude. V_{Ca} has two components, V_{Cad} and V_{Caq} . The voltage in-phase with the current (V_{Cad}) is required to regulate the dc bus voltage and also to meet the power loss in the VSI of DVR and an injection transformer^[5]. The voltage in quadrature with the current (V_{Caq}) is required to regulate the load voltage (V_L) at constant magnitude. During swell event, the injected voltage (V_{Ca}) is such that the load voltage lies on the locus of the circle as shown in Figure-3 (b).

CONTROL OF DVR

The compensation for voltage sags using a DVR can be performed by injecting/absorbing reactive power or real power. When the injected voltage is in quadrature with the current at the fundamental frequency, compensation is achieved by injecting reactive power and the DVR is self-supported with dc bus. But, if the injected voltage is in phase with the current, DVR injects real power and hence a battery is required at the dc side of VSI. The control technique adopted should consider the limitations such as the voltage injection capability (inverter and transformer rating) and optimization of the size of energy storage. Figure-4 shows the control block of the DVR in which the synchronous reference frame (SRF) theory is used for the control of self-supported DVR. The voltages at PCC (V_t) are converted to the rotating reference frame using the abc-dqo conversion. The harmonics and the oscillatory components of voltages are eliminated using low pass filters (LPF). The components of voltages in d-axis and q-axis are,

$$V_{sd} = V_{sd\ dc} + V_{sd\ ac} \quad V_{sq} = V_{sq\ dc} + V_{sq\ ac}$$

The compensating strategy for compensation of voltage quality problems considers that the load terminal voltage should be of rated magnitude and undistorted.

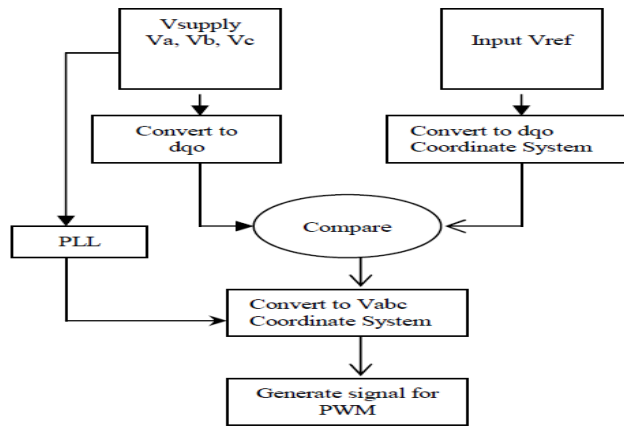

$$\begin{bmatrix} v_q \\ v_d \\ v_0 \end{bmatrix} = \begin{bmatrix} \cos \theta & \cos\left(\theta - \frac{2\pi}{3}\right) & \cos\left(\theta + \frac{2\pi}{3}\right) \\ \sin \theta & \sin\left(\theta - \frac{2\pi}{3}\right) & \sin\left(\theta + \frac{2\pi}{3}\right) \\ 1/2 & 1/2 & 1/2 \end{bmatrix} \begin{bmatrix} v_a \\ v_b \\ v_c \end{bmatrix} \dots 1$$

$$\begin{bmatrix} v_a^* \\ v_b^* \\ v_c^* \end{bmatrix} = \begin{bmatrix} \cos \theta & \sin \theta & 1 \\ \cos\left(\theta - \frac{2\pi}{3}\right) & \sin\left(\theta - \frac{2\pi}{3}\right) & 1 \\ \cos\left(\theta + \frac{2\pi}{3}\right) & \sin\left(\theta + \frac{2\pi}{3}\right) & 1 \end{bmatrix} \begin{bmatrix} v_q^* \\ v_d^* \\ v_0^* \end{bmatrix} \dots 2$$

The dqo transformation or Park's transformation [6] is used to control of DVR. The dqo method gives the sag depth and phase shift information with start and end times. The quantities are expressed as the instantaneous space vectors.

Firstly convert the voltage from a-b-c reference frame to d-q-o reference. For simplicity zero phase sequence components is ignored.

Illustrates a flow chart of the feed forward dqo transformation for voltage sags/swells detection. The detection is carried out in each of the three phases. The control is based on the comparison of a voltage reference and the measured terminal voltage (V_a , V_b , V_c). The voltage sags is detected when the supply drops below 90% of the reference value whereas voltage swells is detected when supply voltage increases up to 25% of the reference value. The error signal is used as a modulation signal that allows generating a commutation pattern for the power switches (IGBT's) constituting the voltage source converter. The commutation pattern is generated by means of the sinusoidal pulse width modulation technique (SPWM); voltages are controlled through the modulation. The speed of the response is determined by parameters K , K_p

and K_v . These parameters control transient as well as steady state behavior of the filter. There exists a compromise between speed and accuracy. For large K and $K_p K_v$, the convergence of the estimated values to actual values is faster but the steady state misadjustment is higher. This is an inherent characteristic of an adaptive algorithm. Parameters ought to be selected appropriately according to the application. Increasing the value of K increases the speed. However, it creates oscillations in the peak detection response. There is a trade-off between speed and accuracy (or smoothness). Decreasing K and $K_p K_v$ yields an estimation of the peak which is insensitive / robust to the undesirable variations and noise in the input signal. The presented PLL provides the following advantages online estimation of the amplitude, phase and their corresponding time derivatives of the pre-selected component of the input signal are provided.

MATLAB MODELLING AND SIMULATION

The DVR is modeled and simulated using the MATLAB and its Simulink and Sim Power System toolboxes. The MATLAB model of the DVR connected system is shown in fig. below. The three-phase programmable source is connected to the three-phase load through the DVR in order to generate sag, swell and harmonics in supply side. The Considered load is a lagging power factor load. The VSI of the DVR is connected to the system using an injection transformer. In addition, a ripple filter for filtering the switching ripple in the terminal voltage is connected across the terminals of the secondary of the transformer. The dc bus capacitor of DVR is selected based on the transient energy requirement and the dc bus voltage is selected based on the injection voltage level. The dc capacitor decides the ripple content in the dc voltage. The system data are given in Appendix.

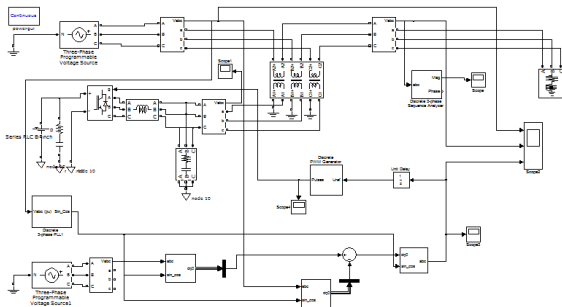

Figure-5: MATLAB model of DVR connected system

The control algorithm for the DVR is simulated in MATLAB. The control algorithm shown in Fig.-4 is modelled for DVR control of Fig.-5. The reference load voltages are derived from the sensed terminal voltages, load supply voltages and the dc bus voltage of the DVR. A pulse width modulation (PWM) controller is used over the reference and sensed load voltages to generate gate signals for the IGBT's of the VSI.

PERFORMANCE OF THE DVR SYSTEM

The performance of the DVR is demonstrated for different supply voltage disturbances such as sag and swells in supply voltage [3]. A case of Three-phase voltage sag is simulated and the results are shown in Figure-6. Figure-6(a) shows 50% voltage sag initiated at 150 ms and it is kept until 300 ms, with total voltage sag duration of 150 ms. Figure-3(b) and (c) show the voltage injected by the DVR and the compensated load voltage, respectively. As a result of DVR, the load voltage is kept at 1 p.u. throughout the simulation, including the voltage sag period. It is observed that during normal operation, the DVR is not operational. It quickly injects necessary voltage components to smoothen the load voltage upon detecting voltage sag.

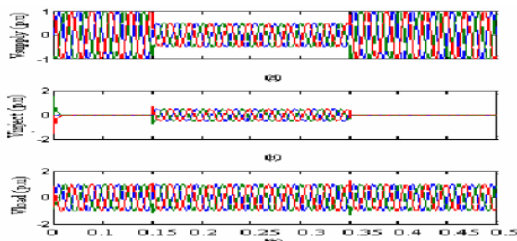

Fig.-6 (a) Supply Side Voltage with 50% voltage sag, Fig.-6(b) Compensated Voltage injected by DVR

Figure-7(a) shows the transient performance of the system under voltage sag and swell conditions. At 0.12 sec, a sag in supply voltage is created for the duration of 0.13sec and at 0.3 sec a swell in supply is created for the duration of 0.1sec. It is observed that the load voltage is regulated to constant amplitude under both sag and swell conditions. Figure-7(b) shows the in-phase injection of voltage by the DVR. The load voltage is maintained sinusoidal by injecting proper compensation voltage by the DVR shown in Figure-7(c).

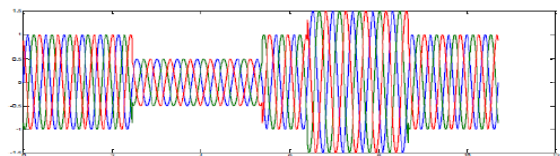

Fig.-7 (a) Supply Side Voltage with 50% voltage Sag and 50% voltage Swell

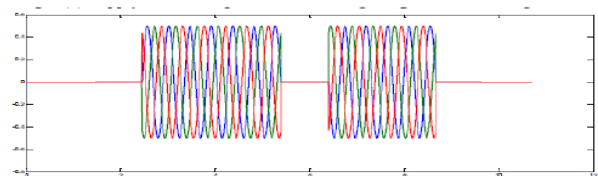

Fig.-7 (b) Compensated Voltage injected by DVR for compensating voltage

Figure-8 (a) shows the first simulation was done with no DVR and a three phase fault is applied to the system at point with fault resistance of 0.66 U for a time duration of 200 ms. Figure-8(b) shows The second simulation is carried out at the same scenario as above but a DVR is now introduced at the load side to compensate the voltage sag occurred due to the three phase fault applied.

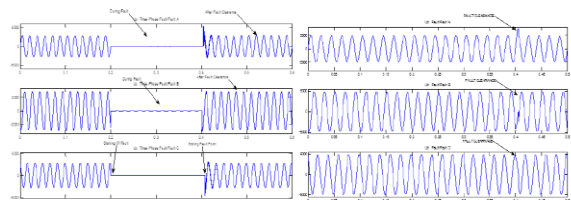

Fig.-8 (a) Three phase fault without DVR Fig.-8 Three phase fault with DVR voltage compensation

Appendix

AC line voltage: 415 V, 50 Hz Load: 10KVA, 0.80 pf lag PI Controller: $K_p = 5$ $K_i = 120$ DC

voltage of DVR: 300V Harmonic Filter: $L_r = 2.0\text{mH}$, $C_r = 10\mu\text{F}$, $R_r = 4.8\Omega$ PWM Switching Frequency: 1080Hz Injection Transformer: Turns Ratio=1:1 Inverter: IGBT based 3 arms, 6 Pulse, Frequency=1080 Hz, Sample Time= 5 μs DC Bus Capacitance of DVR: 1000 μF

CONCLUSION

The study of DVR is focused on applying a new sag detection method and a new compensating voltage generation method. The conventional sag detection method is unable to detect the voltage sags lower than a definite level. As an instance, a single phase to ground fault resulting voltage sag cannot be determined by this method because the method used the average of the three phase voltage and sees the single phase voltage sag as an average value of three phases. To overcome the disadvantages of the conventional sag detection method, the proposed method is used in this paper. With the proposed method, the controller is able to detect different types of power quality problems without an error and injects the appropriate voltage component to correct immediately any abnormality in the terminal voltage to keep the load voltage balanced and constant at the nominal value. Simulation and experimental results show that, the proposed DVR successfully protects the most critical load against voltage sags. Moreover it has been found that DVR is capable of providing a self-support to its dc bus by taking active power from the ac line.

REFERENCES

1. Power Quality Problems and New Solutions by A. de Almeida, L. Moreira, J. Delgado
2. Math H.J. Bollen, Understanding power quality problems: voltage sags and interruptions, IEEE Press, New York, 2000
3. Performance of DVR under different voltage sag and swell conditions by T. Devaraju, V. C. Reddy and M. Vijaya Kumar
4. Voltage Quality Improvement Using DVR by Chellali BENACHAIBA, Brahim FERDI
5. Adaline-Based Control of Capacitor Supported DVR for Distribution System Bhim Singh*, P. Jayaprakash†, and D. P. Kothari
6. Control of three level inverter based DVR by 1S.LEELA, S.DASH
7. Rating and Design Issues of DVR Injection Transformer by Sasitharan S., Mahesh K. Mishra, Member, IEEE, B. Kalyan Kumar, and Jayashankar V., member, IEEE
8. Particle Swarm Optimization based Dynamic Voltage Restorer
9. Power Quality Enhancement Using Custom Power Devices by A. Ghosh and G. Ledwich. 2002. Kluwer Academic Publishers.
10. FACTS controllers in power transmission and distribution by K. R. Padiyar
11. S. Chen, G. Joos, L. Lopes, and W. Guo. 2000. A nonlinear control method of dynamic voltage restorers in 2002 IEEE 33rd Annual Power Electronics Specialists Conference. pp. 88- 93.
12. Voltage quality enhancement with custom power park by Mehmet Emin MERAL
13. The Effect of DVR Location for Enhancing Voltage Sag by Rohanim Ibrahim, Ahmed M. A. Haidar, Zahim M., Herbert Iu
14. Modeling and simulation for voltage sags/swells mitigation using DVR by Rosliomar, Nasrudin Abd Rahim, Marizan Sulaiman
15. Control of Reduced Rating Dynamic Voltage Restorer with Battery Energy Storage System, || by B. Sing, P. Joyprakash
16. H. Akagi, E H Watanabe and M Aredes, Instantaneous power theory and applications to power conditioning, John Wiley and Sons, New Jersey, 2007.